

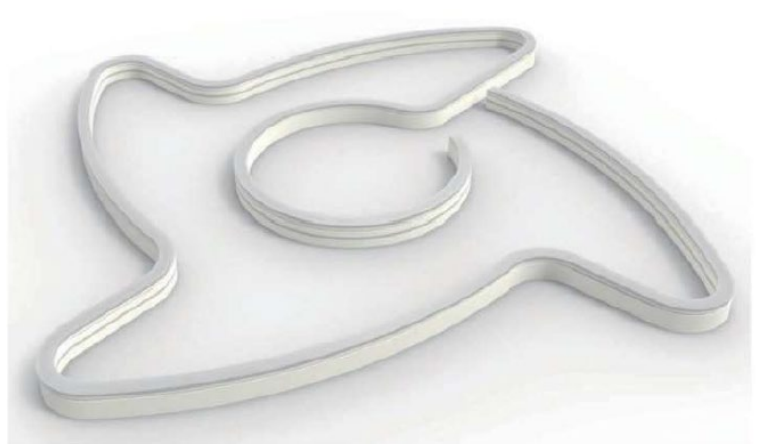

Client Date Qty
Project Type PO#

LS-EXT-NEON-SIDE-10*18

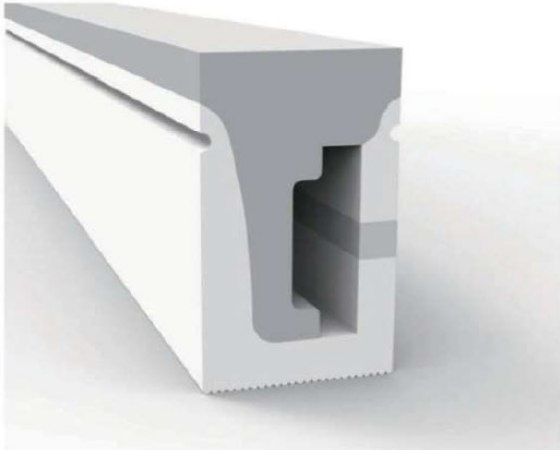

Description

- Robust silicone design.
- Flexible from the sides.
- Resists tension during handling.
- Designed for optimal diffusion without visible dots.
- Indoor or outdoor use.
- IP67 protection.
- Compatible with all our 10mm LED strips.
- Consistency of color temperature (Kelvin)
- Possibility of up to 60 feet with LS-STRIP-24V-LL tape

Compatible LED TAPE

Compatible with all our
10mm LED TAPE





Client Date Qty
Project Type PO#

LS-EXT-NEON-SIDE-10*18

Dimensions

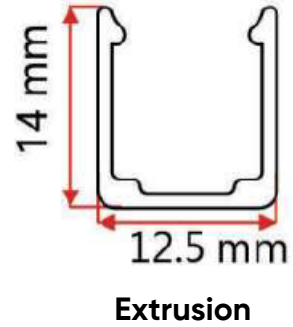
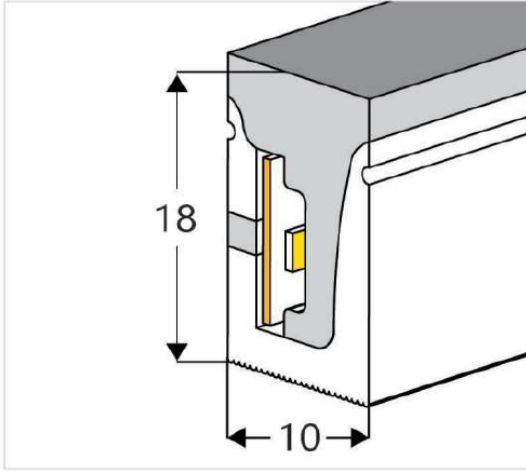

Installation

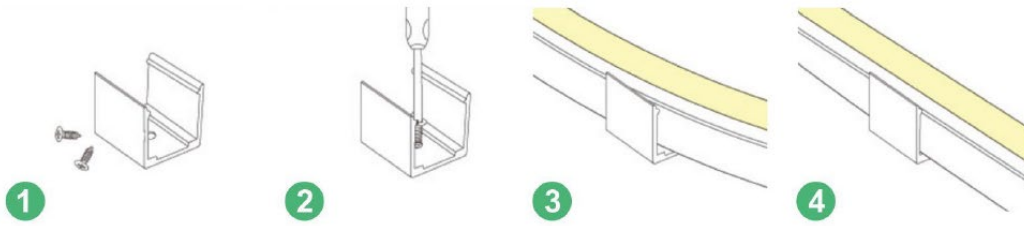

Accessories



END CAP H

END CAP NH

CLIP

EXTRUSION

FLEXIBLE EXTRUSION